

Service Differentaition and QoS in WLANs (802.11e)

Renato Lo Cigno
www.dit.unitn.it/locigno/didattica/NC/

...Copyright

Quest'opera è protetta dalla licenza *Creative Commons NoDerivs-NonCommercial*. Per vedere una copia di questa licenza, consultare:
<http://creativecommons.org/licenses/nd-nc/1.0/>
oppure inviare una lettera a:
Creative Commons, 559 Nathan Abbott Way, Stanford, California 94305, USA.

This work is licensed under the *Creative Commons NoDerivs-NonCommercial* License. To view a copy of this license, visit:
<http://creativecommons.org/licenses/nd-nc/1.0/>
or send a letter to
Creative Commons, 559 Nathan Abbott Way, Stanford, California 94305, USA.



What's the Problem in PCF

- PCF designed to provide QoS to real-time traffic
- What makes QoS in 802.11 difficult?
 1. Unpredictable beacon delay
 - A WSTA stops all timers at TBTT thus it does not initiate a transmission after TBTT; however, it continues on-going transmissions, hence beacon may be delayed
 - The larger the frame size, the longer the delay (up to 4.9 ms)
 2. Unknown transmission duration
 3. Static Polling List



Quality-of-Service Provisioning: Some Terminology

- **Definition:** A **flow** is a packet stream from a source to a destination, belonging to the same application
- **Definition:** **QoS** is a set of service requirements to be met by the network while transporting a flow
- Typical QoS metrics include: available bandwidth, packet loss rate, estimated delay, packet jitter, hop count and path reliability



QoS in Wireless Networks

- QoS schemes in wired networks are NOT suitable for wireless networks
 - e.g., current wired-QoS routing algorithms require accurate link state and topology information
 - time-varying capacity of wireless links, limited resources and node mobility make maintaining accurate information difficult
- Supporting QoS in wireless networks is an even more difficult challenge



Service Differentiation MAC Schemes that lead to 802.11e

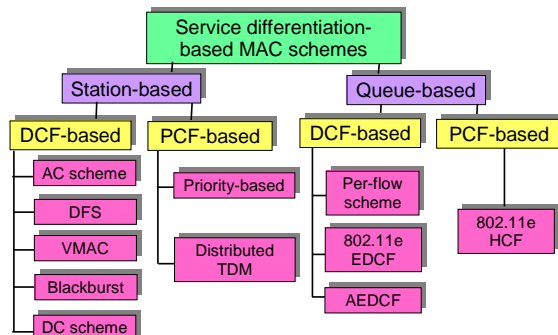

A QoS Standard for WLANs: IEEE 802.11e

- The IEEE 802.11 TG E was formed in 1999
- The Project Authorization Request (PAR) was approved in March 2000
- **Scopes of the IEEE 802.11 Task Group E**
 - Enhance the current 802.11 MAC to improve and manage QoS
 - Consider efficiency enhancements in the areas of DCF and PCF
 - Provide different classes of service (8 TCs)

Renato.LoCigno@dit.unitn.it
Thanks: TLC Networks Group – Politecnico di Torino
Nomadic Communications: 802.11e 7

802.11e Standard

- Released last autumn
- PHY unchanged (use a/b/g)
- MAC Enhanced: Goals
 - Traffic Differentiation and Guarantee
 - TSPEC and CAC
 - Interoperation with legacy 802.11

Renato.LoCigno@dit.unitn.it
Thanks: TLC Networks Group – Politecnico di Torino
Nomadic Communications: 802.11e 8

802.11e: QSTA, QAP, QBSS, HCF

- A station using 802.11e is called *QoS Enhanced Station (QSTA)*
- An AP using 802.11e is called *QoS Access Point (QAP)*
- QSTA e QAP works within a *QoS Basic Service Set (QBSS)*
- The two coordination functions DCF e PCF are substituted by a single *Hybrid Coordination Function (HCF)*

Renato.LoCigno@dit.unitn.it
Thanks: TLC Networks Group – Politecnico di Torino
Nomadic Communications: 802.11e 9

TXOPs

- **TXOP: Transmission Opportunity**
 - Time interval during which a QSTA has the right to transmit
 - It is characterized by a starting time and a maximum duration (TXOP_Limit)
 - Used in both CP and CFP



802.11e Coordination Function

- Hybrid Coordination Function, alternates:
 - EDCA (Enhanced Distributed Channel Access), contention based, conceived to support legacy stations and provide some *stochastic* level of differentiation
 - HCCA (HCF Coordinated Channel Access), polling based, provides collision free periods with guaranteed assignment and *deterministic* differentiation



802.11e QoS Mechanisms

802.11e proposes a new access scheme: **Hybrid Coordination Function (HCF)**, composed of two coordination functions

- **Enhanced Distributed Channel Access (EDCA)**
 - A basis layer of 802.11e; operates in CP
- **HCF Controlled Channel Access (HCCA)**
 - HCCA operates in CFP

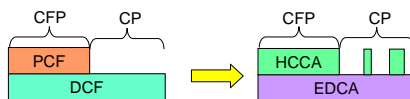

802.11e QoS Mechanisms

- MAC-level FEC (Hybrid I and II)
- Ad hoc features:
 - Direct Communication / Side Traffic
 - WARP: Wireless Address Resolution Protocol
 - AP mobility



802.11e: Hybrid Coordinator

- Within a QBSS a centralized controller is needed to coordinate all QSTAs. This is the *Hybrid Coordinator (HC)*, normally implemented within a QAP
- An HC has the role of splitting the transmission superframe in two phases continuously alternating:
 - *Contention Period (CP)*, where QSTAs contend for the channel using EDCA
 - *Contention-Free Period (CFP)*, where HC defines who is going to use the channel and for what time with a collision free polling protocol



MAC 802.11e: HCCA

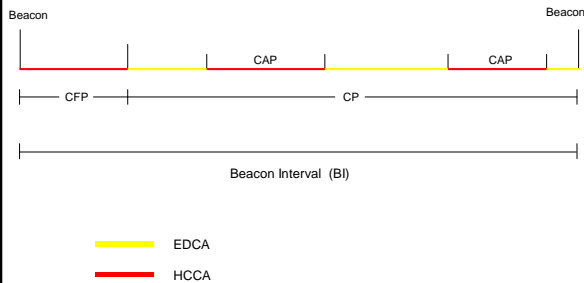

802.11e: EDCF

- L'Enhanced Distributed Coordination Function (EDCF) define a differentiated access scheme based on an improved (yet complex) contention scheme
- It is an evolution of CSMA/CA DCF, with the add-on of traffic classes to support QoS and differentiate traffic
- EDCF is designed to support frames with the same 8 priority levels of 802.11d, but mapping them on only 4 access categories
- Every frame passed to the MAC layer from above, must have a priority identifier (from 0 to 7), called *Traffic Category Identification (TCId)*



802.11e: EDCF

- TCId is written in one header field of the MAC frame
- Each 802.11e QSTA & QAP MUST have four separated AC queues
- Each AC queue is FIFO and behaves independently from the others as far as the CSMA/CA MAC protocol is concerned



802.11e: EDCF

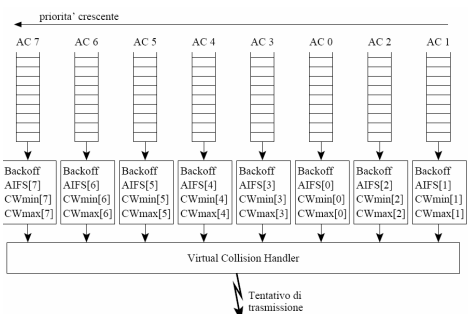

802.11e: EDCF

- ACs are differentiated based on their CSMA parameters:
 - **IFS**
 - **CWmin**
 - **CWmax**
 - **Backoff exponent**



802.11e: EDCF

- Higher priority ACs are assigned parameters that result in shorter CWs so that a statistical advantage is gained in access in the channel
- Protocol parameters become vectors
 - $CWmin[AC]$
 - $CWmax[AC]$
 - $AIFS[AC]$
 - $bck[AC]$
- $CW[AC,t]$ is derived with the usual CSMA/CA rules



802.11e: EDCF

- Arbitration InterFrame Space (AIFS) substitute the common DIFS
- Each AIFS is at least DIFS long
- Before entering the backoff procedure each *Virtual Station* will have to wait $AIFS[AC]$, instead of DIFS



Virtual Stations

- Each AC queue behaves like a different virtual station (independent sensing and backoff)
- If the backoff counters of two or more parallel ACs in the same QSTA reach 0 at the same time, a scheduler inside the QSTA avoids virtual collision by granting the TXOP to the AC with the highest UP
- The lowest priority colliding behaves as if there were an external collision



802.11e: EDCF – Beacon Frames

- Values of $AIFS[AC]$, $CWmin[AC]$ e $CWmax[AC]$ are determined by the QAP and transmitted within beacon frames (normally every 100 msec)
- QSTAs must abide to the received parameters
- QSTAs may use these parameters to chose the QAP the prefer to connect to (estimate of the expected performance)



802.11e: EDCF – Virtual Collisions

- Every AC within a QSTA behaves as if it were an independent station, with its own MAC parameters $AIFS[AC]$ e $CW[AC]$
- So Virtual Stations (AC queues) within a QSTA contend for the channel
- Internal collisions between different ACs are solved virtually, without loss of resources
- The TXOP goes to the highest priority AC and the others behave as if there was a real collision



802.11e: EDCF – Collisioni Virtuali

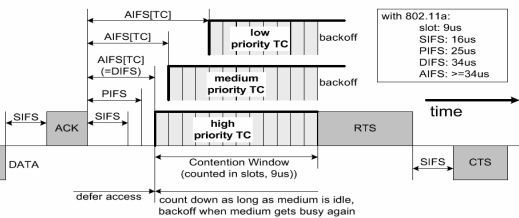

Renato.LoCigno@dit.unitn.it

Thanks: TLC Networks Group – Politecnico di Torino

Nomadic Communications: 802.111e 28

802.11e: TXOP

- TXOP is the time interval in which a STA may use the channel
- It's an initial time plus a duration, indeed the negotiation is no more for a PDU, but can be for many aggregated PDUs (this part is not well defined in the standard)
- CW[AC] is managed with usual rules of increment (after collisions/failures) and devrement (during idle cahnnel):

$$\text{NewCW[AC]} = ((\text{OldCW[AC]} + 1) * 2) - 1$$



Renato.LoCigno@dit.unitn.it

Thanks: TLC Networks Group – Politecnico di Torino

Nomadic Communications: 802.111e 29

802.11e: EDCF

- Sample allocation of TCID to ACs:

TCID	CA	Traffic description
0	0	Best Effort
1	0	Best Effort
2	0	Best Effort
3	1	Video Probe
4	2	Video
5	2	Video
6	3	Voice
7	3	Voice



Renato.LoCigno@dit.unitn.it

Thanks: TLC Networks Group – Politecnico di Torino

Nomadic Communications: 802.111e 30

EDCA Bursting

- Once the station has gained access to the medium, it can be allowed to send **more than one frame** without contending again
- The station cannot transmit longer than **TXOP_Limit**
- **ACK frame by frame or Burst ACK**
- **SIFS** is used between packets (to avoid collisions)



EDCA Bursting: Pros / Cons

- **Pros**
 - Reduces network **overhead**
 - **Increases throughput** (SIFS and burst ACKs)
 - **Better fairness** among the same priority queues: independently of the frame size, a QSTA gets a TXOP every time it wins a contention
 - E.g., STA A uses 500 B frame; STA B uses 1K B frame. Thus B would get higher throughput in 802.11, while in 802.11e both can get approximately same throughput



EDCA Bursting: Pros / Cons

- **Cons**
 - Possible increasing of **delay jitter**
 - TXOP_Limit should not be longer than the time required for transmitting the largest data frame
- In any case EDCA does not solve the downlink/uplink unfairness problem



802.11e: HCF

- HC may allocate TXOPs to himself (QAP) or to other QSTAs
- Self allocation is done to transmit MSDUs, allocation of resources may solve the uplink/downlink unfairness
- Allocation to AP can be done after a Point coordination InterFrame Space (PIFS) con $PIFS < DIFS$
- HC (QAP) has priority over other stations and may interrupt a CP to start a CFP transmitting a Poll frame



802.11e: HCF

- Time is divided between contention free periods (CFP) and contention periods (CP), that are alternated roughly cyclically
- A sequence CFP + CP defines a Periodic Superframe of 802.11e
- The CP can be interrupted by other contention free periods called CAPs



802.11e: HCF

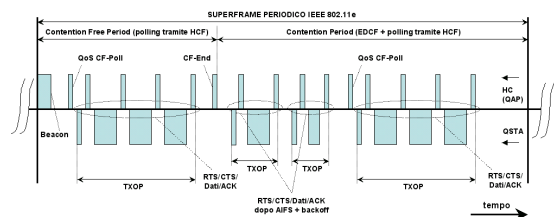

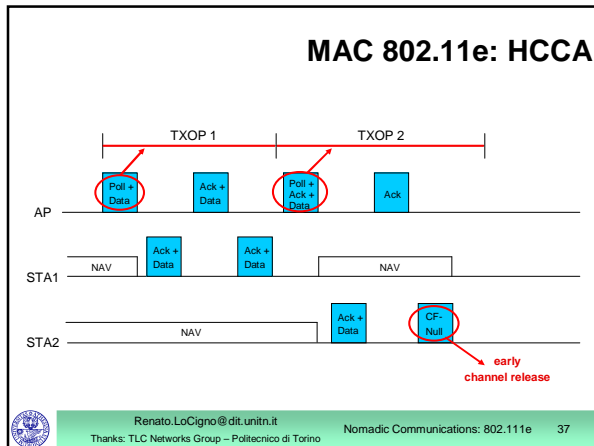

802.11e: HCF – QoS CFPoll Frame

- Within a CP, TXOP is determined either:
 - Through EDCF rules (free channel + AIFS + BO + TXtime)
 - Through a poll frame, called QoS CFPoll, sent by HC to a station
- QoS CFPoll is sent after PIFS, so with priority wrt any other traffic
- Indeed there is not a big difference between a CFP and CAPs as defined above.

The bottom of the slide includes the text: 'Renato.LoCigno@dit.unitn.it Thanks: TLC Networks Group - Politecnico di Torino Nomadic Communications: 802.111e 38'.

802.11e: HCF – QoS CFPoll Frame

- During CFP, TXOPs are again determined by HC and QoS CFPoll can be piggybacked with data and ACKs if needed
- Stations not polled set NAV and cannot access the channel
- The CFP must terminate within a time specified within the beacons and it is terminated by the CF-End frame sent by HC

The bottom of the slide includes the text: 'Renato.LoCigno@dit.unitn.it Thanks: TLC Networks Group - Politecnico di Torino Nomadic Communications: 802.111e 39'.

802.11e: HCF – QoS CFPoll Frame

- QoS CF-Poll frame was introduced with the 802.11e amendment, for backward compatibility it contains a NAV field the legacy stations can use to avoid interfering
- NAV specify the whole TXOP duration
- Legacy stations in HCF can only use the CP period



802.11e: HCF – Controlled Content.

- Is a mix between polling and contention based
- Should guarantee better performances than contention during congestions periods
- The *Controlled Contention* mechanism is mandatory for QAP an optional for QSTA:
 - QSTA notify QAP some allocation requests, QAP sill allocate the necessary TXOPs via polling
 - DIfferent from standard polling, because it'



802.11e: HCF – Controlled Content.

- QAP defines if there are resources to satisfy requests:
 - If available schedules the channel (IEEE 802.11e does not specify scheduling algorithms, these are open for research and competitive implementation)
 - The answer to stations can be acceptance, rejections or a proposal to use resources with a lower priority



HCCA

- HCCA effectively provides policing and deterministic channel access by controlling the channel through the HC
- It is backward compatible with basic DCF/PCF
- Based on polling of QSTAs by the HC

Renato.LoCigno@dit.unitn.it
Thanks: TLC Networks Group – Politecnico di Torino
Nomadic Communications: 802.111e 43

HCCA

Crucial features of HCCA

- HCCA operates in CP and CFP
- Uses TXOPs which are granted through HC (in HCCA!)
 - HC allocates TXOPs by using QoS CF-Poll frames
 - In CPs, the time interval during which TXOPs are polled by HC is called CAP (Controlled Access Period)
 - 8 Traffic Categories (TCs)

Renato.LoCigno@dit.unitn.it
Thanks: TLC Networks Group – Politecnico di Torino
Nomadic Communications: 802.111e 44

HC Behavior in HCCA

- According to HCCA:
 - HC may allocate TXOPs to itself to transmit MSDUs whenever it wants, however only after having sensed the channel idle for PIFS
 - In CP, the HC can send the CF-Poll frame after a PIFS idle period, thus starting a CAP
 - In CFP, only the HC can grant TXOPs to QSTAs by sending the CF-Poll frame
 - The CFP ends after the time announced by HC in the beacon frame or by the CF-End frame from HC



Renato.LoCigno@dit.unitn.it
Thanks: TLC Networks Group – Politecnico di Torino
Nomadic Communications: 802.111e 45

QSTA Behavior in HCCA

- A QSTA behaves as follows
 - In CP QSTAs can gain a TXOP thanks to a CF-Poll frame issued by HC during CAPs, otherwise they can use EDCA
 - In CFP, QSTAs do not attempt accessing the channel on their own but wait for a CF-Poll frame from the HC
- The HC indicates the TXOP duration to be used in the CF-Poll frame (QoS-control field)
 - Legacy stations kept silent by NAV whenever they detect a CF-Poll frame

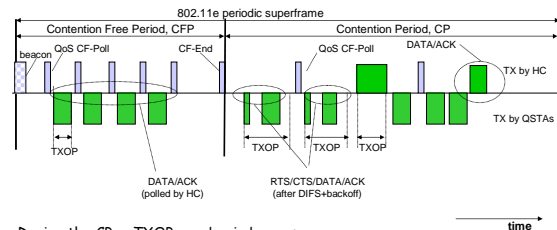

802.11e Superframe



During the CP, a TXOP may begin because:

- The medium is determined to be available under EDCA rules (EDCA-TXOP)
- The STA receives a special polling frame from HC (polled-TXOP)



Polling in HCCA

- Polling list is a crucial key in HCCA
 - Traffic scheduling (i.e., how QSTAs are polled) is not specified
 - QSTAs can send updates to the HC on their queue size as well as on the desired TXOP, (through the QoS control field in data frames)
 - QSTAs can send ADDTS requests to initiate a new traffic stream



Traffic Signaling

- Two types of signaling traffic are supported:
 - Connectionless queue state indicator
 - E.g., Arrival rate measurement: notification and not negotiation between **peer entities** is used
 - TSPEC (Traffic Specification) between HC and QSTAs
 - E.g., service negotiation and resource reservation



Traffic Signaling

- TSPEC are the base for CAC
- QoS without CAC is impossible
- QoS is granted to flows not to packets
- Flows are persistent (normally)
- Flows can be predicted (sometimes)



Resource Scheduling

- Not essential to backward compatibility
 - The standard has just a reference impl. (SS)
- HCF is implemented in the AP
 - HCCA scheduling is a function of HCF
- Requirements of traffic flows are contained in the *Traffic Specifications* (TSPEC):
 - Maximum, minimum and mean datarate
 - Maximum and nominal size of the MSDUs
 - Maximum Service Interval and **Delay Bound**
 - Inactivity Interval
 - ...