



# Wireless Mesh and Vehicular Networks

# Simulation of Vehicular Networks

Michele Segata, Renato Lo Cigno - University of Trento

with special thanks to

Falko Dressler, Christoph Sommer, Bastian Bloessl, Stefan Joerer, David Eckhoff



# A (rough) outline of the Vehicular Networks topics

- ~~Application: why VN?~~
- ~~Communication: technologies, alternatives, protocols, challenges~~
- Simulation: evaluating vehicular networks without vehicles and without networks. Tools and models



# SIMULATION

- Field Operational Tests

- + Highest degree of realism
- no in-depth investigations of network behavior
- Non-suppressible side effects
- Limited extrapolation from field operational tests



- Analytical evaluation

- + Closed-form description allows for far-reaching conclusions
- May need to oversimplify complex systems

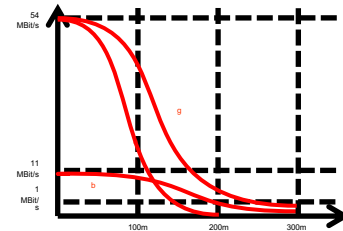

- Simulation

- Can serve as middle ground

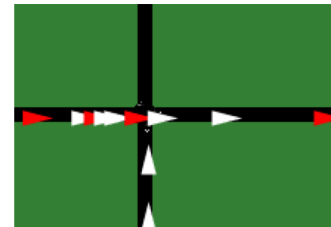





- Models
  - Network protocol layers
  - Radio propagation
  - Node mobility
  - Model of approach to be investigated (e.g., flooding)
- Scenarios
  - Road geometry, traffic lights, meta information
  - Normal traffic pattern
  - Scenario of use case to be investigated (e.g., accident)
- Metrics
  - Network traffic metrics (delay, load, ...)
  - Road traffic metrics (travel time, stopping time, emissions, ...)
  - Metric of use case to be investigated (e.g., time until jam resolved)

- Dedicated simulation tools
  - Discrete Event Simulation (DES) kernel
  - Manages queue of events (e.g., “an IP fragment was received”)
  - Delivers events to simulation models
- Model libraries
  - Simulate components’ reaction to events
  - E.g., HTTP server, TCP state machine, radio channel, human, ...
  - “when enough IP fragments received  $\Rightarrow$  tell TCP: packet received”

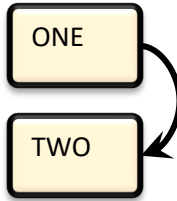

| Engine      | Language | Library     | Language               |
|-------------|----------|-------------|------------------------|
| OMNeT++     | C++      | MiXiM       | C++                    |
| ns-2 / ns-3 | C++      | ns-2 / ns-3 | Objective Tcl / Python |
| JiST        | Java     | SWANS       | Java                   |

- Simple model: unit disk
  - Fixed radio “range”
  - Node within range  
⇔ packet received
  
- Enhanced models:
  - For each packet, consider
    - Signal strength
    - Interference (other radios)
    - Noise (e.g., thermal noise)
  - Calculate “signal to noise and interference ratio” (SNIR)
  - Derive packet error rate (PER)

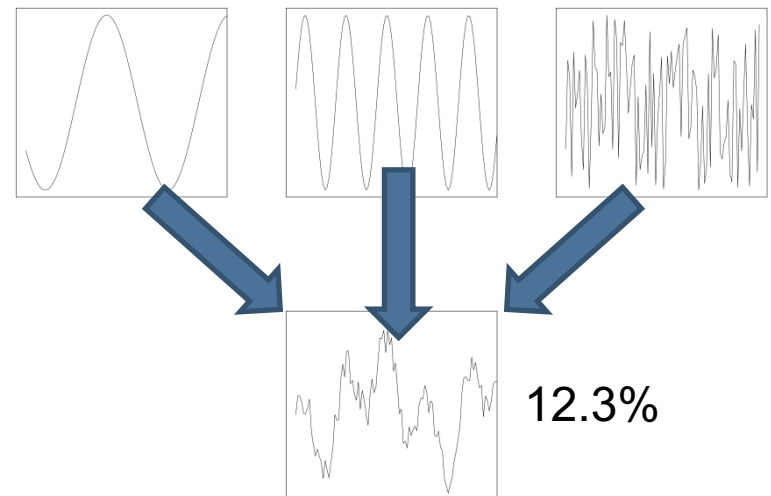
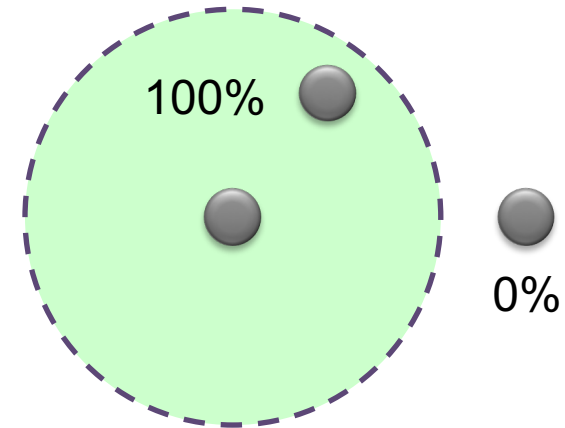



- Signal attenuation
  - Received power depends on transmitted power, antenna gains, and path loss

$$P_r[\text{dBm}] = P_t[\text{dBm}] + G_t[\text{dB}] + G_r[\text{dB}] - \sum L_x[\text{dB}]$$

- Free space path loss

$$L_{\text{freespace}}[\text{dB}] = 20 \lg \left( 4\pi \frac{d}{\lambda} \right)$$

- Empirical free space path loss

$$L_{\text{freespace,emp}}[\text{dB}] = 10 \lg \left( 4\pi \frac{d}{\lambda} \right)^\alpha$$

- Two Ray Interference path loss

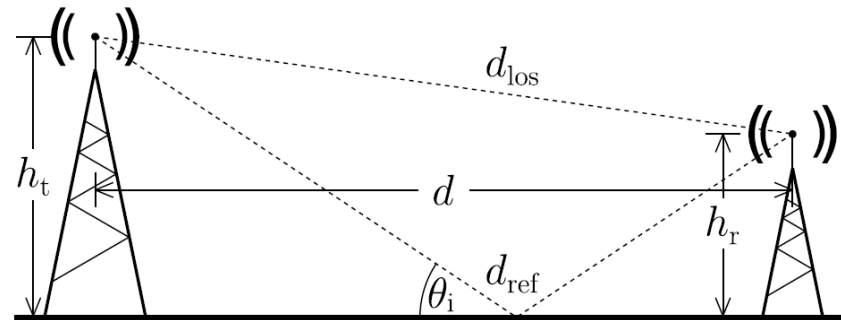

$$L_{\text{tri}}[\text{dB}] = 20 \lg \left( 4\pi \frac{d}{\lambda} \left| 1 + \Gamma_{\perp} e^{i\varphi} \right|^{-1} \right), \text{ substituting}$$

$$\varphi = 2\pi \frac{d_{\text{los}} - d_{\text{ref}}}{\lambda}, \quad \Gamma_{\perp} = \frac{\sin \theta_i - \sqrt{\epsilon_r - \cos^2 \theta_i}}{\sin \theta_i + \sqrt{\epsilon_r - \cos^2 \theta_i}},$$

$$d_{\text{los}} = \sqrt{d^2 + (h_t - h_r)^2}, \quad d_{\text{ref}} = \sqrt{d^2 + (h_t + h_r)^2},$$

$$\sin \theta_i = (h_t + h_r) / d_{\text{ref}}, \quad \cos \theta_i = d / d_{\text{ref}}.$$

- Comparison: Two Ray Interference vs. Free Space

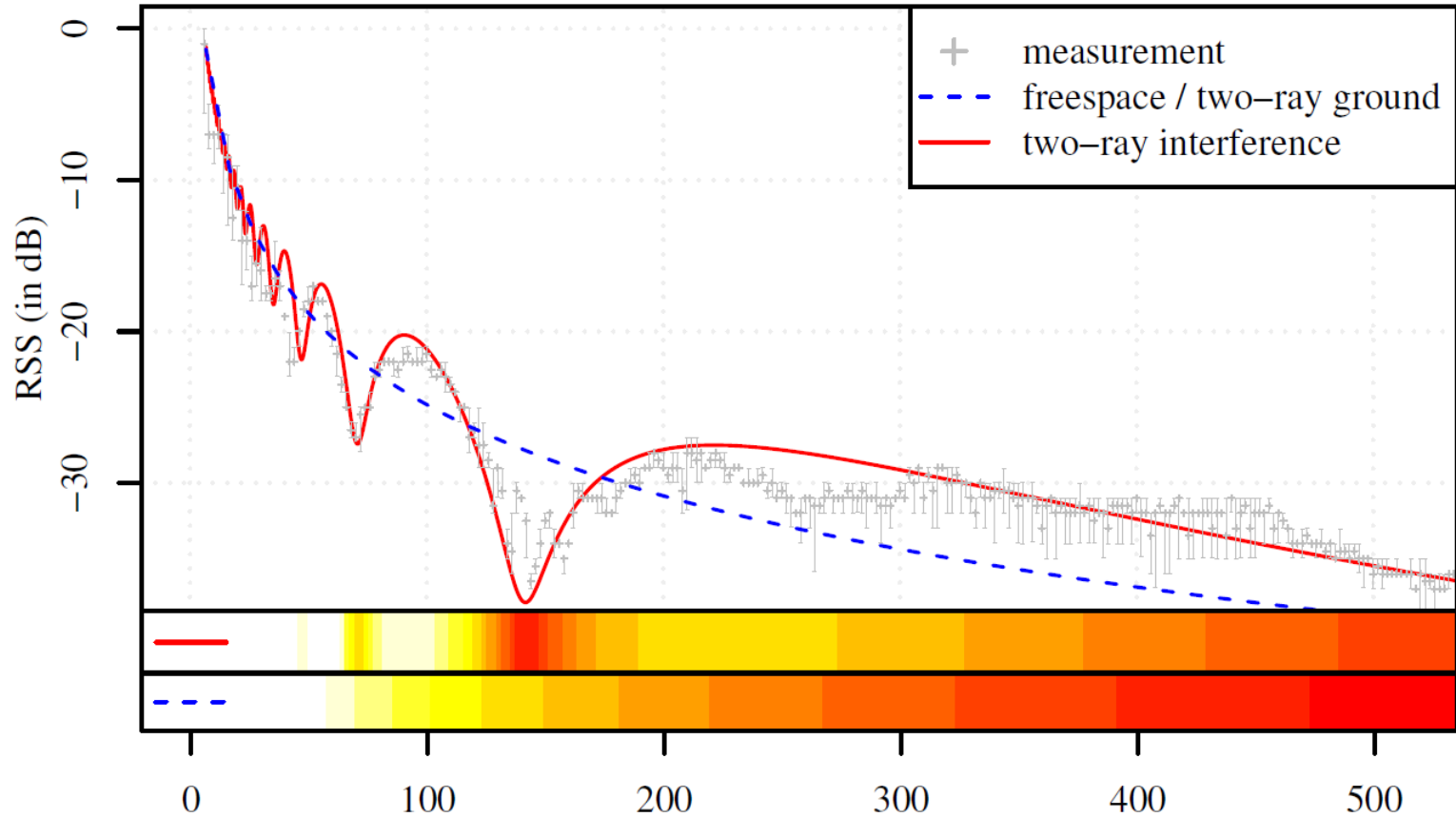

- Traditional approach in network simulation:  
Random Waypoint (RWP)
  - „pick destination, move there, repeat“
- First adaptation to vehicular movement
  - Add mass, inertia
  - Add restriction to “roads”
  - Add angular restrictions
- Problem
  - Very unrealistic (longitudinal) mobility pattern

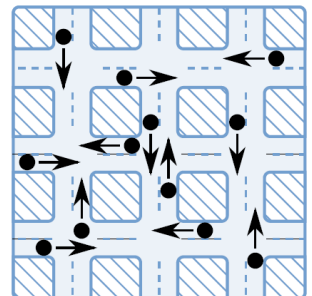
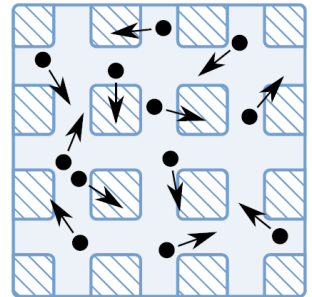
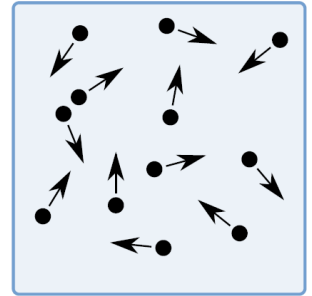

[1] J. Yoon, M. Liu, and B. Noble, "Random waypoint considered harmful," Proceedings of 22nd IEEE Conference on Computer Communications (IEEE INFOCOM 2003), vol. 2, San Francisco, CA, March 2003, pp. 1312-1321

- First approach: Replay recorded trace data
  - Use GPS
  - Install in Taxi, Bus, ...
  - Highest degree of realism

- Problems:
  - Invariant scenario
  - No extrapolation
    - To other vehicles (cars, trucks, ...)
    - To more vehicles
    - To fewer vehicles

B. Real-world traces

Network Simulation

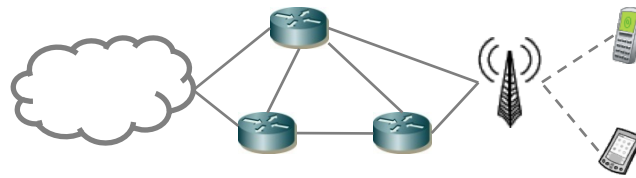

- [1] V. Naumov, R. Baumann, and T. Gross, "**An evaluation of inter-vehicle ad hoc networks based on realistic vehicular traces**," Proceedings of 7th ACM International Symposium on Mobile Ad Hoc Networking and Computing (ACM Mobihoc 2006), Florence, Italy, March 2006, pp. 108-119
- [2] M. Fiore, J. Härri, F. Filali, and C. Bonnet, "**Vehicular Mobility Simulation for VANETs**," Proceedings of 40th Annual Simulation Symposium (ANSS 2007), March 2007, pp. 301-309
- [3] H-Y. Huang, P-E. Luo, M. Li, D. Li, X. Li, W. Shu, and M-Y. Wu, "**Performance Evaluation of SUVnet With Real-Time Traffic Data**," IEEE Transactions on Vehicular Technology, vol. 56 (6), pp. 3381-3396, November 2007



- Replay artificial trace data
  - Microsimulation of road traffic
  - Pre-computation or live simulation
  - Problem: how to investigate traffic information systems (TIS)?

## Network Simulation

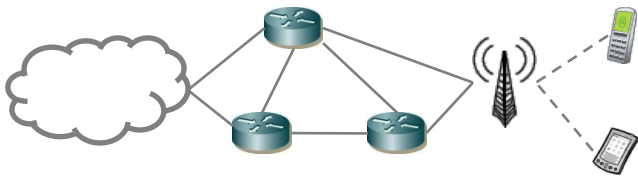

C. Micro-simulation

## Road Traffic Simulation

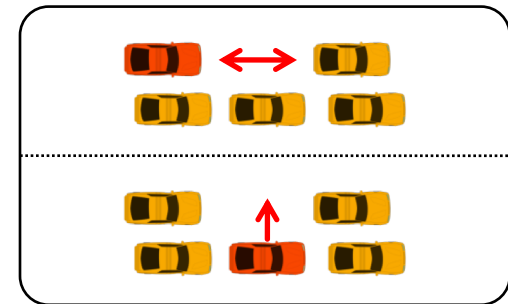

- [1] C. Sommer, I. Dietrich, and F. Dressler, "**Realistic Simulation of Network Protocols in VANET Scenarios**," Proceedings of 26th IEEE Conference on Computer Communications (INFOCOM 2007): IEEE Workshop on Mobile Networking for Vehicular Environments (MOVE 2007), Poster Session, Anchorage, AK, May 2007, pp. 139-143
- [2] B. Raney, A. Voellmy, N. Cetin, M. Vrtic, and K. Nagel, "**Towards a Microscopic Traffic Simulation of All of Switzerland**," Proceedings of International Conference on Computational Science (ICCS 2002), Amsterdam, The Netherlands, April 2002, pp. 371-380
- [3] M. Treiber, A. Hennecke, and D. Helbing, "**Congested Traffic States in Empirical Observations and Microscopic Simulations**," Physical Review E, vol. 62, pp. 1805, 2000

- Bidirectional coupling
  - Network traffic can influence road traffic

## Network Simulation

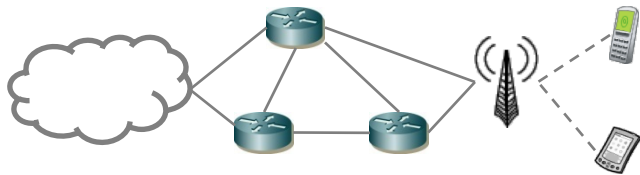

D. Bidirect.  
coupling

## Road Traffic Simulation

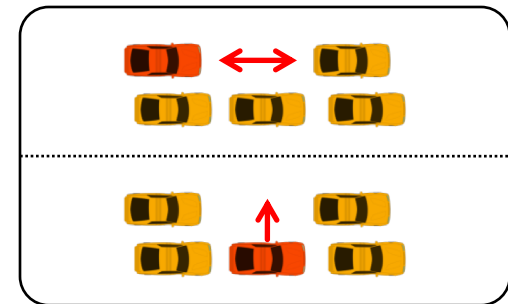

[1] C. Sommer, Z. Yao, R. German, and F. Dressler, "On the Need for Bidirectional Coupling of Road Traffic Microsimulation and Network Simulation," Proceedings of 9th ACM International Symposium on Mobile Ad Hoc Networking and Computing (Mobihoc 2008): 1st ACM International Workshop on Mobility Models for Networking Research (MobilityModels 2008), Hong Kong, China, May 2008, pp. 41-48

[2] C. Sommer, R. German, and F. Dressler, "Bidirectionally Coupled Network and Road Traffic Simulation for Improved IVC Analysis," IEEE Transactions on Mobile Computing, 2010. (to appear)

- Road traffic microsimulation
  - Ex.: SUMO – Simulation of Urban Mobility
  - Time discrete microsimulation
  - Car following models (Krauss, IDM)
  - Lane change models
  - Road topology
    - Speed limits
    - Traffic lights
    - Access restrictions
    - Turn restrictions
    - ...

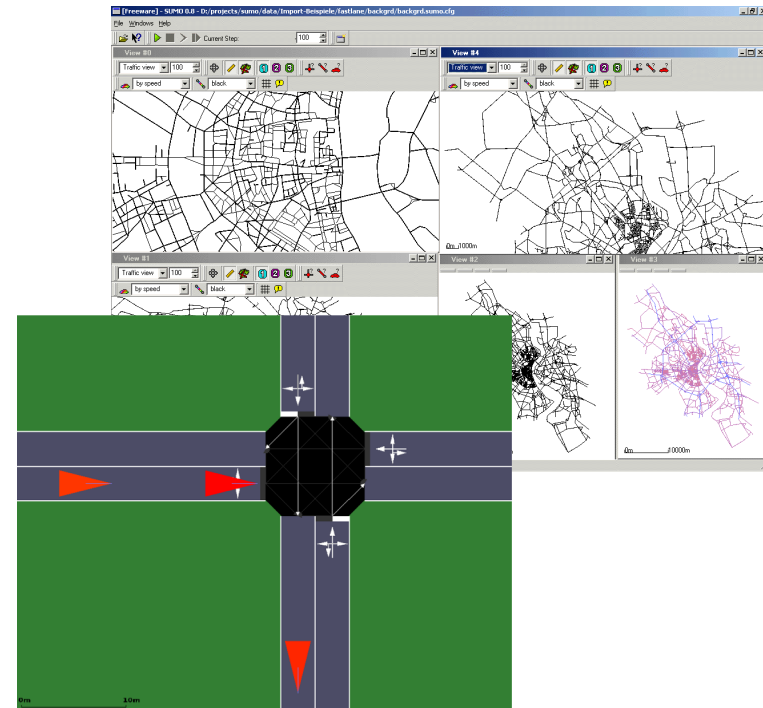

[1] D. Krajzewicz, G. Hertkorn, C. Rössel, and P. Wagner, "**SUMO (Simulation of Urban MOBility); An open-source traffic simulation,**" Proceedings of 4th Middle East Symposium on Simulation and Modelling (MESM2002), Sharjah, United Arab Emirates, September 2002, pp. 183-187

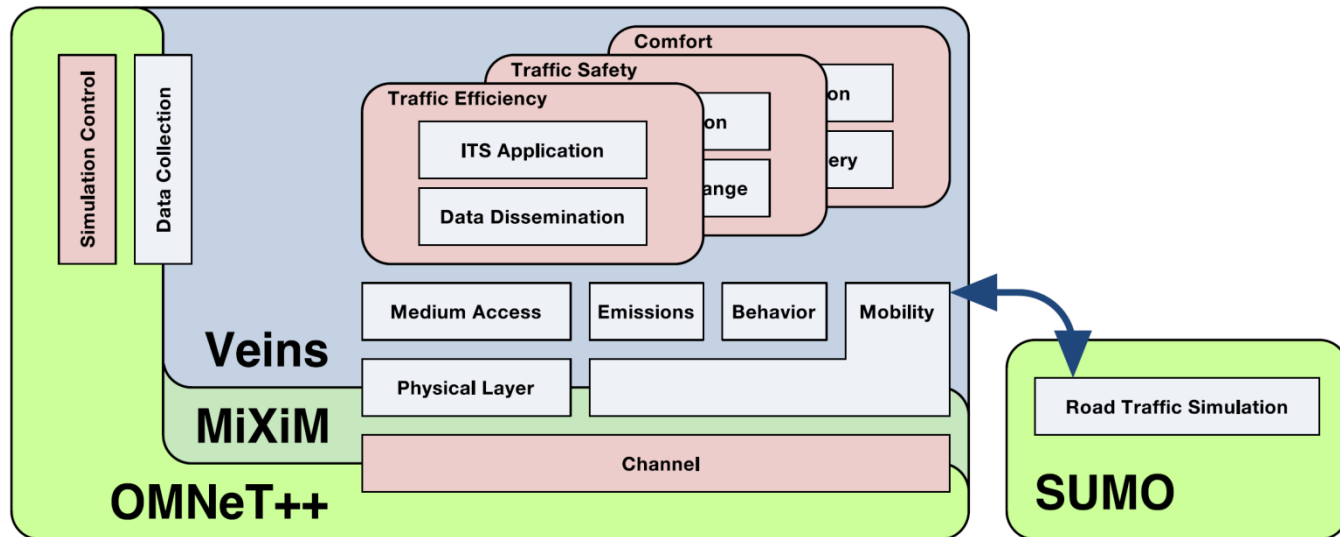

[1] C. Sommer, R. German, and F. Dressler, "Bidirectionally Coupled Network and Road Traffic Simulation for Improved IVC Analysis," IEEE Transactions on Mobile Computing, vol. 10, no. 1.

[2] C. Sommer, Z. Yao, R. German, and F. Dressler, "Simulating the Influence of IVC on Road Traffic using Bidirectionally Coupled Simulators," in 27th IEEE Conference on Computer Communications (INFOCOM 2008), Phoenix, AZ: IEEE, April 2008.

- OMNeT++
  - Discrete-Event Simulation (DES) kernel
    - Simulate model's reaction to queue of events
  - Main use case: network simulation
    - e.g., MANETs, Sensor nodes
  
- (Fork of) MiXiM
  - Model library for OMNeT++ for PHY layer and mobility support
  - Event scheduling
  - Signal propagation
  - SINR / bit error calculation
  - Radio switching
  - ...

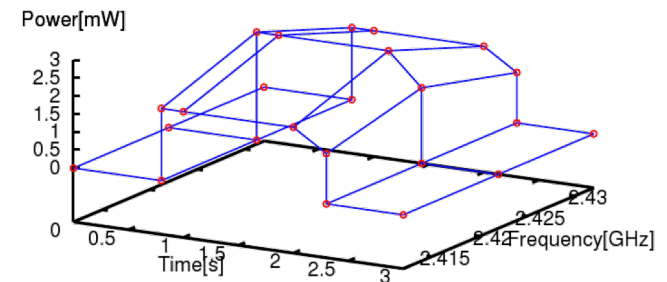

[1] A. Varga, "The OMNeT++ Discrete Event Simulation System," Proceedings of European Simulation Multiconference (ESM 2001), Prague, Czech Republic, June 2001

- Coupling OMNeT++ and SUMO
  - Synchronize time steps
  - Exchange commands and status information

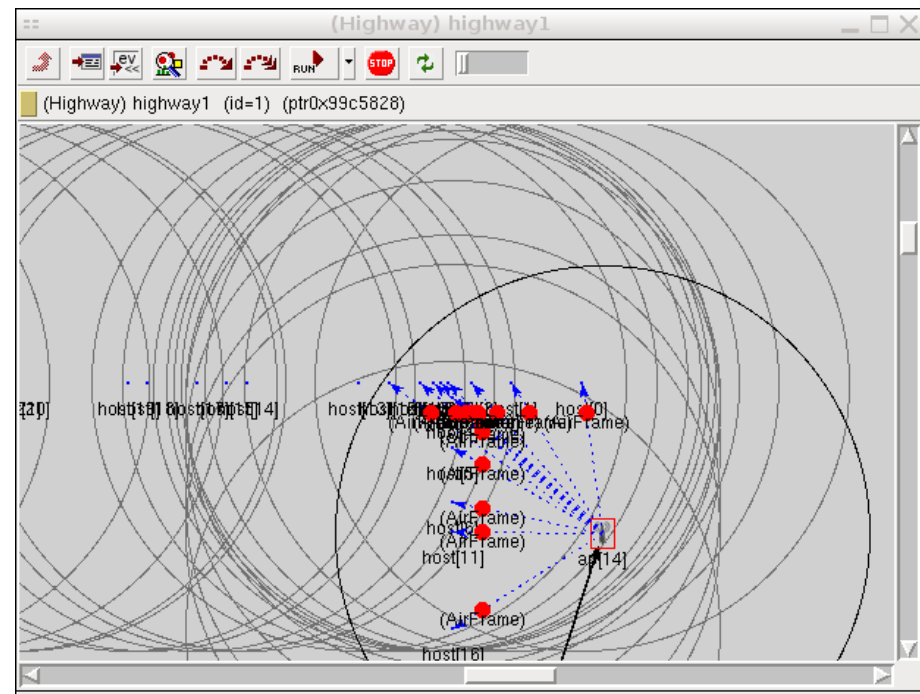
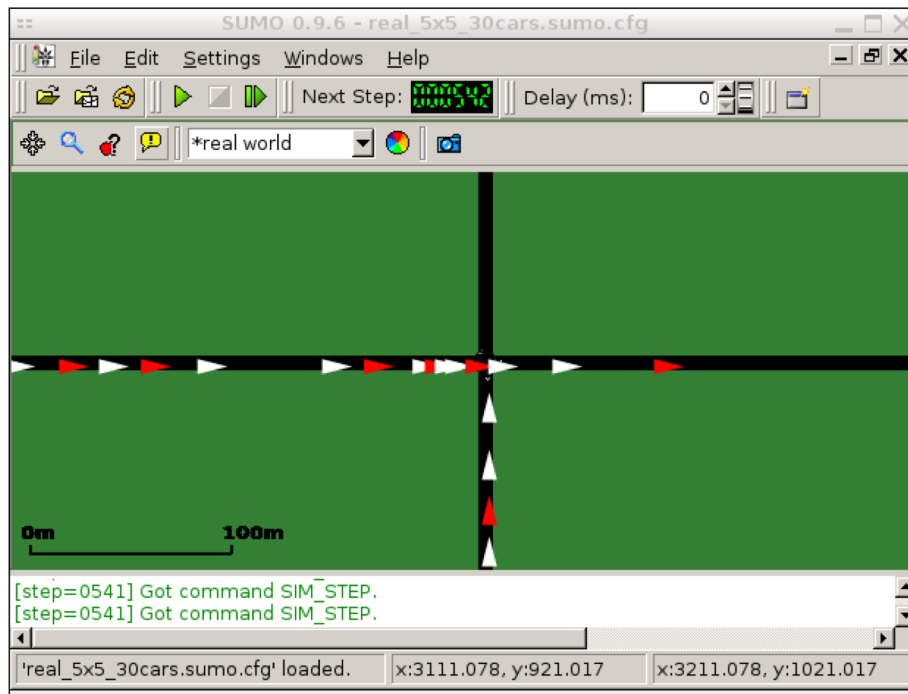

- TraCI: Message Sequence Chart

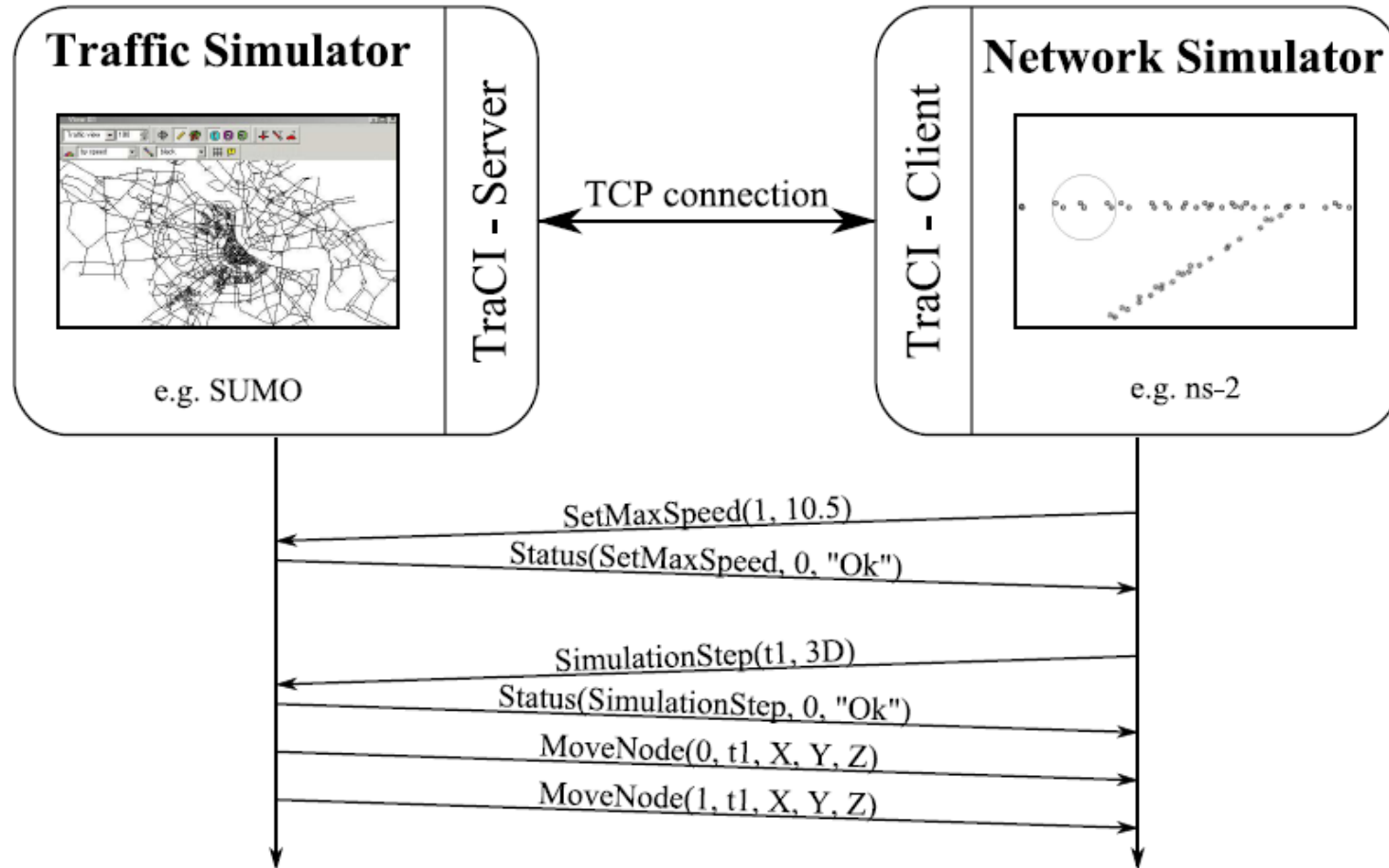



- Freely available road topology information
  - Geodatabase of OpenStreetMap project

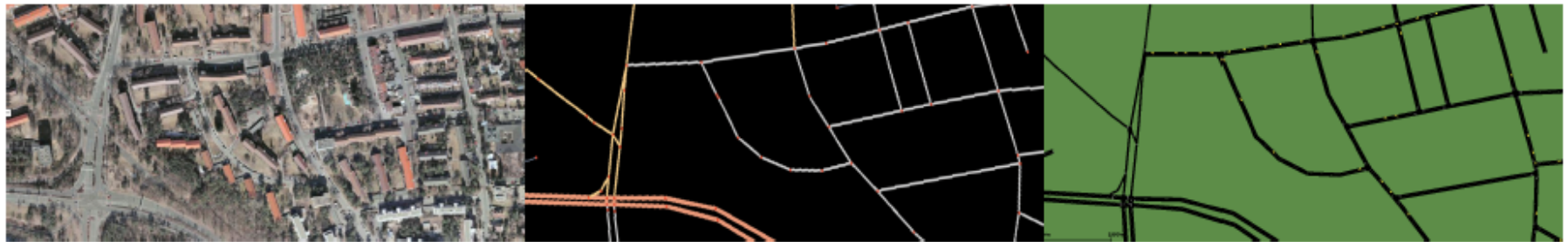
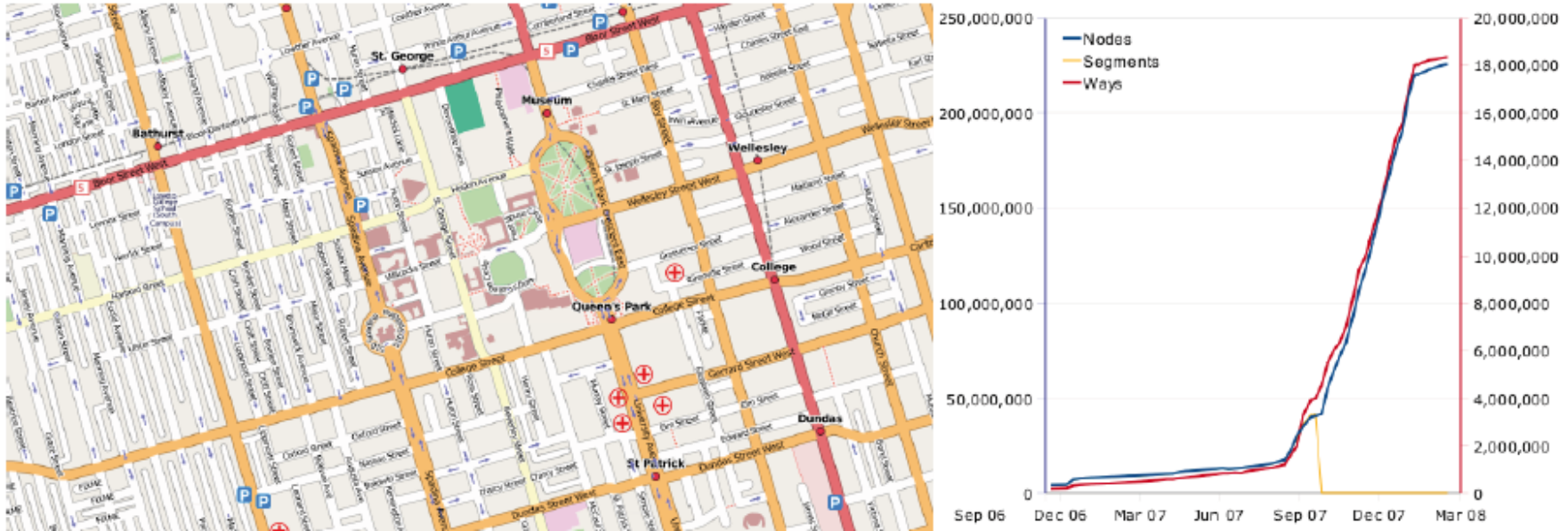





A little bit of background

# DISCRETE EVENT SIMULATION



- Simulation: reproducing the behavior of a real-world system
  - mathematical
    - $a(t) = a_0$
    - $v(t) = a_0 * t + v_0$
    - $x(t) = a_0/2 * t^2 + v_0 * t + x_0$
  - numerical
    - $a[k] = a_0$
    - $v[k] = v[k-1] + a_0 * dT$ , with  $v[0] = v_0$
    - $x[k] = x[k-1] + (v[k] + v[k-1])/2 * dT$ , with  $x[0] = x_0$

- Discrete simulation: simulation “exists” only in specific time moments
  - time driven: sampled with a certain frequency (e.g., 10 Hz)



- event driven: evolution by the generation and the consumption of events

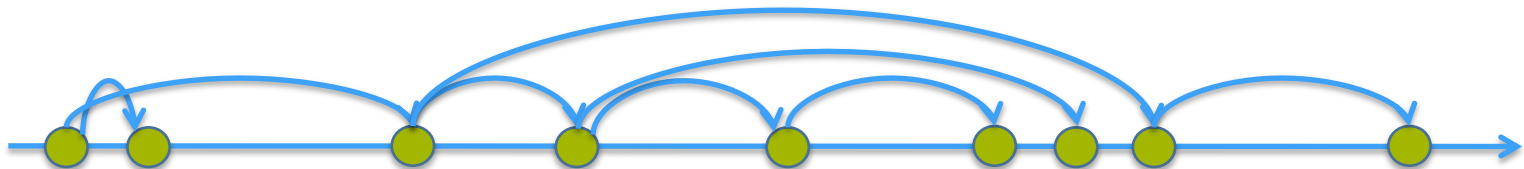

- Very easy example: two nodes communication

on init:

```
scheduleEvent(sendMsg, now + exp(1))
messageCount = 0
```

on event(event):

```
if (event == sendMsg) {
    send(packet)
    scheduleEvent(sendMsg, now + exp(1))
} else {
    if (random() > 0.5)
        messageCount++
}
```

on finish:

```
saveToFile(messageCount)
```

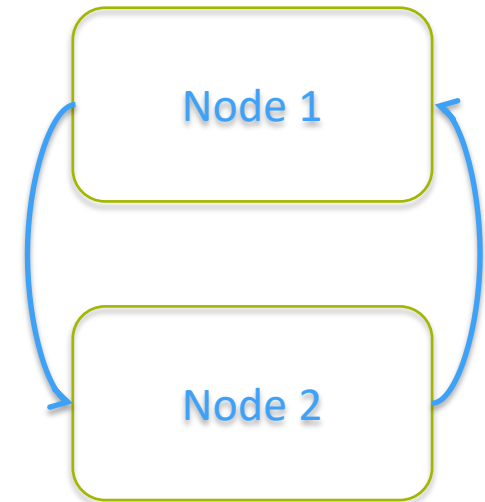

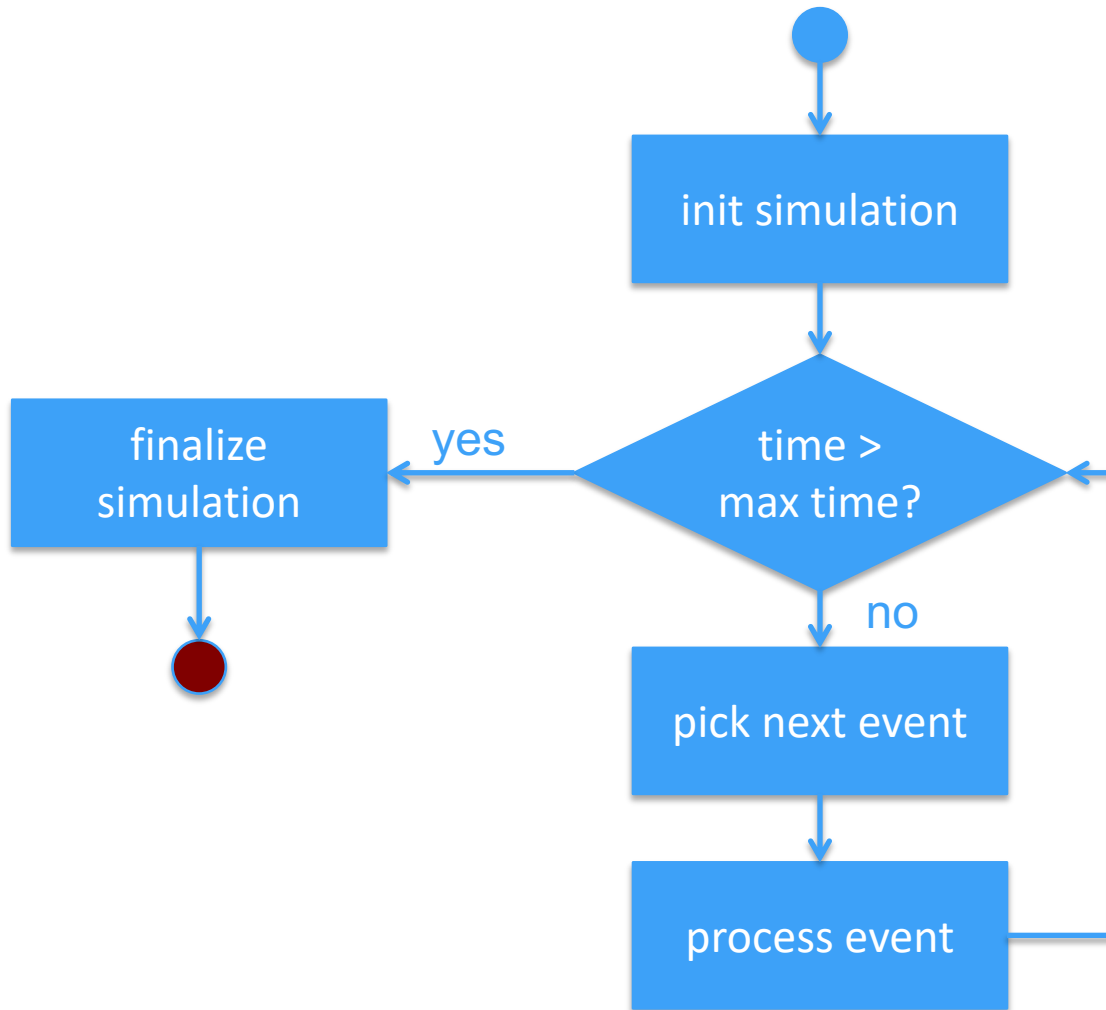



- Be careful: philosophy change needed
  - EVERYTHING is an event
    - schedule events
    - handle events
  - events are atomic
    - no duration

**WRONG!**

```
onStartRx:  
  beginRx = now  
  wait(endOfTransmission)  
  rxDuration = now - beginRx
```

**CORRECT!**

```
onStartRx:  
  beginRx = now  
  
onEndRx:  
  rxDuration = now - beginRx
```

- Consider again a network simulation
  - managing collisions: when two packets overlap, they both can't be received



```
onInit:
  state = IDLE
  recvPackets = {}
```

```
onStartRx(packet):
  recvPackets.add(packet)
  if (state == IDLE)
    state = RX
  else
    for p in recvPackets
      p.setLost()
```

```
onEndRx(packet):
  if (not packet.isLost())
    sendUp(packet)
  recvPackets.del(packet)
  if (|recvPackets| == 0)
    state = IDLE
```



The core network simulator

**OMNET++**





- Discrete Event Simulator
  - mainly used for network simulations
  - free for academic usage
  - multi-platform and open source
  - provides IDE for programming (if needed)
  - provides GUI for simulations (if needed)



- Programming OMNeT++ means creating modules:
  - NED: textual files defining parameters and gates of the module
  - C++: source file defining the behavior of the module
  - example: Protocol.ned, Protocol.h, Protocol.cc
  - in addition: .msg (message files)
- Modules interconnect through gates
- You can define compound modules that do not require a C++ implementation
- You can implement C++ classes with no NED
- NED files support inheritance

- Good for coding, but NEVER build source code from there or run them, except for debugging

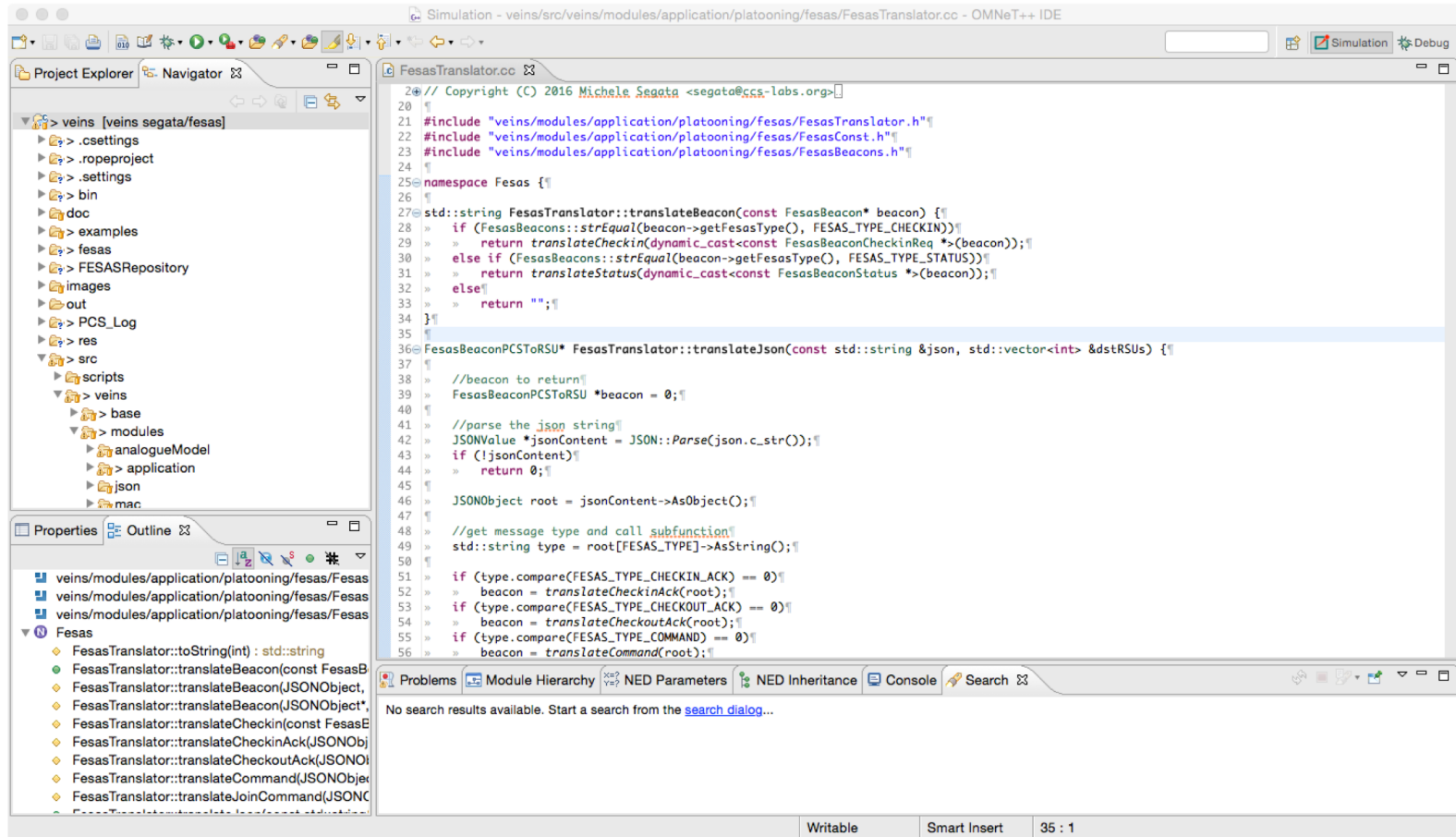

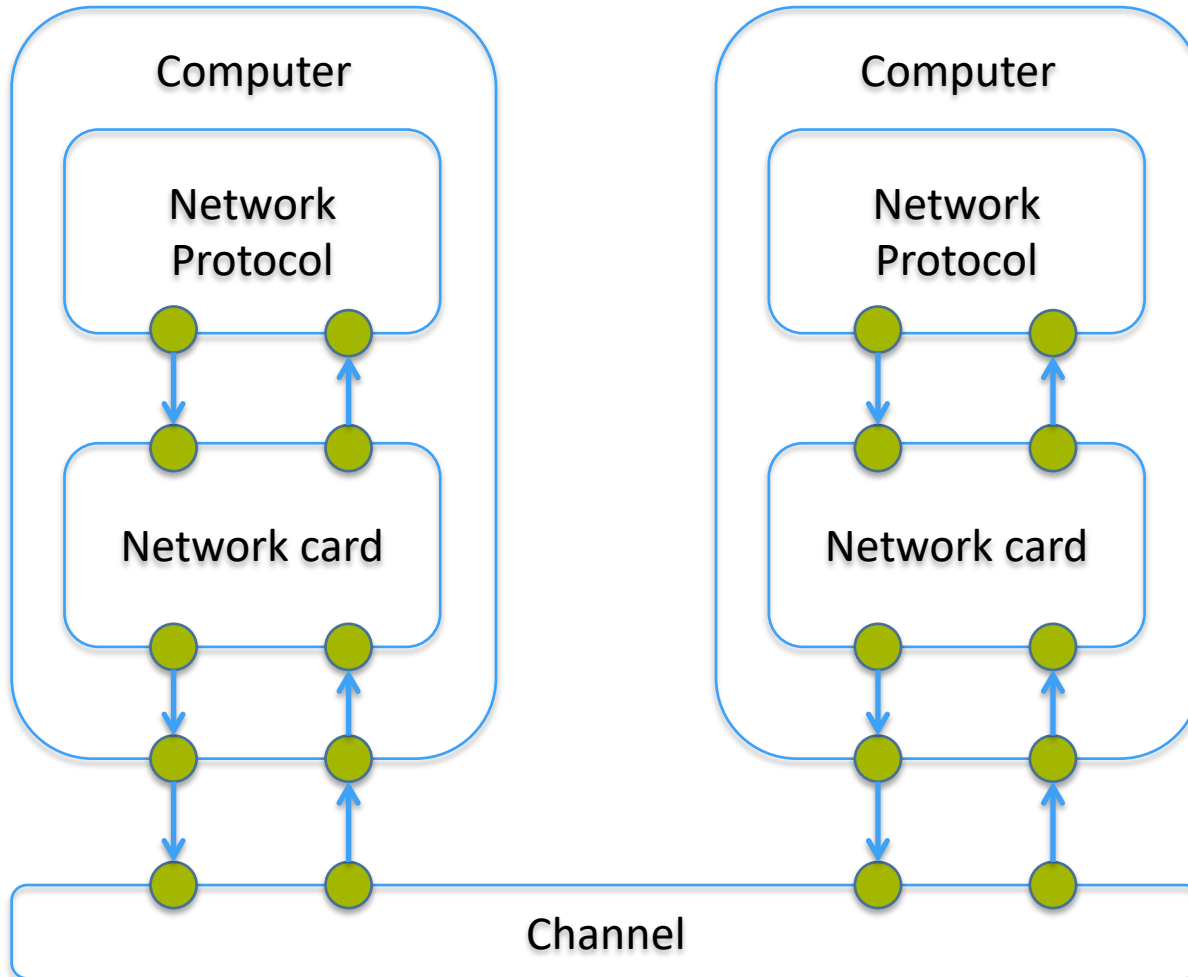



```
package org.car2x.veins.modules.application.platooning;

import org.car2x.veins.modules.application.ieee80211p.BaseWaveApplLayer;

simple UnicastProtocol extends BaseWaveApplLayer
{
    parameters:
        //maximum queue size. set to 0 for infinite queue
        int queueSize = default(0);
        //maximum number of attempts
        int maxAttempts = default(16);
        //ack timeout
        double ackTimeout @unit(s) = default(1ms);
        //packet loss rate (between 0 and 1)
        double packetLossRate = default(0);

        @class(UnicastProtocol);
        @display("i=msg/mail");

    gates:
        input upperControlIn;
        output upperControlOut;
        input upperLayerIn;
        output upperLayerOut;
}
```



# Compound module example

```
import org.car2x.veins.base.modules.IBaseApplLayer;
[...]
import org.car2x.veins.modules.nic.Nic80211p;

module Car {
  parameters:
    string scenario_type;
    string helper_type;
    string appl_type;
    string protocol_type;
  gates:
    input radioIn; // gate for sendDirect
  submodules:
    [...]
    appl: <appl_type> like BaseApp {}
    prot: <protocol_type> like BaseProtocol {}
    unicast: UnicastProtocol {}
    nic: Nic80211p {}
    mobility: TraCIMobility {}
  connections allowunconnected:
    unicast.upperControlIn <-- prot.lowerControlOut;
    unicast.upperControlOut --> prot.lowerControlIn;
    unicast.upperLayerIn <-- prot.lowerLayerOut;
    unicast.upperLayerOut --> prot.lowerLayerIn;
    nic.upperLayerIn <-- unicast.lowerLayerOut;
    nic.upperLayerOut --> unicast.lowerLayerIn;

    radioIn --> nic.radioIn;
}
```



- Defined in .msg files

```
message MyMessage {  
    int sourceId;  
    string information;  
}
```

- Automatically transformed into C++ code

```
class MyMessage : public ::cPacket {  
    protected:  
        int sourceId_var;  
        opp_string information_var;  
    public:  
        virtual int getSourceId() const;  
        virtual void setSourceId(int sourceId);  
    [...]
```



- In OMNeT++ you can record data for statistics
  - vector: time sequence of values recorded multiple times
    - `cOutVector speed;`
    - `speed.setName("speed");`
    - `speed.record(<value>);`
  - scalars: single value usually recorded in the `finish()` method
    - `recordScalar("avgSpeed", <value>);`
- To extract data from vectors please see the scripts at
  - <https://github.com/michele-segata/plexo-data-extraction>





- Defines the following methods:
  - initialize(int stage)
  - finish()
  - handleMessage(cMessage \*msg)
- Uses the following methods:
  - simTime()
  - scheduleAt(SimTime t, cMessage \*msg)
  - send(cMessage \*msg, int gateId)
  - cancelEvent(cMessage \*msg)
  - par(const char\* parName)
- Many more things...
  - refer to OMNeT++ documentation



```
*.node[*].nic.mac1609_4.txPower = 100mW
```

```
*.node[*].nic.mac1609_4.bitrate = 6Mbps
```

```
*.node[*].nic.phy80211p.useThermalNoise = true
```

```
*.node[*].nic.phy80211p.thermalNoise = -95dBm
```

```
[Config ConfigName]
```

```
extends = OtherConfig
```

```
repeat = 10
```

```
*.node[*].module.param1 = ${p1 = 1,2}
```

```
*.node[*].module.param2 = ${p2 = 3,4}
```

```
*.node[*].module.param3 = ${p3 = 7,8 ! p1}
```

```
output-vector-file = ${resultdir}/${configname}_${p1}_${p2}_${repetition}.vec
```

```
output-scalar-file = ${resultdir}/${configname}_${p1}_${p2}_${repetition}.sca
```



- Download source code from course website
- Building the example

```
unzip tictoc.zip  
cd tictoc  
make -j <number of cores> MODE=<release,debug>
```

- Running the examples (live demo)

```
cd simulations  
./run [-u Cmdenv] -c TxcSimulation -r 0  
./run [-u Cmdenv] -c Txc2Simulation -r 0
```



- Open the OMNeT++ IDE (type omnetpp in your terminal)
- Click on File -> Import... -> General -> Existing projects into workspace
- Choose the folder where the project is located
- Click Open!
  
- `./run -a`
  - Lists all the configurations with the number of runs
- `./run -x <CONFIGNAME> -g`
  - Lists all the runs for a particular config
  - For each run, it shows the parameters for that specific run



- Content of the tutorial:
  - Simple tic-toc message exchange between two nodes
- Version 1:
  - Upon reception of a message, a response is immediately sent back
- Version 2:
  - Upon reception of a message, a node waits for some time before replying
- Features explored:
  - C/C++ and NED modules, with parameters and gates
  - TicToc.ned network
  - Scheduling events and sending messages through gates
  - omnetpp.ini configuration file with features



# VEINS AND SUMO



- OMNeT++:
  - a Discrete Event Simulator mainly used for network simulations
- SUMO:
  - a time-driven discrete simulator of vehicular mobility
- Veins:
  - a vehicular networking simulation framework
  - couples OMNeT++ and SUMO



1. A vehicle is created in SUMO
  - via SUMO configuration
  - via Veins manual injection
2. Veins is notified
3. Veins creates an OMNeT++ module
  - module type and name defined inside omnetpp.ini or ned files
    - \*.manager.moduleType = "Car"
    - \*.manager.moduleName = "node"
  - possibility to map SUMO vehicle type to specific module
    - \*.manager.moduleType = "vtypeauto=Car vtypeother=OtherCar"
    - \*.manager.moduleName = "vtypeauto=node vtypeother=other"



- Download Veins source code and compile it (after OMNeT++)

```
git clone https://github.com/sommer/veins.git
cd veins
./configure
make -j <number of cores> MODE=<release,debug>
```

- Install SUMO (version 0.32.0)

```
sudo add-apt-repository ppa:sumo/stable
sudo apt-get update
apt-get -s install sumo #check that this would install 0.32.0
sudo apt-get install sumo
```

- Check that SUMO is working by typing:

```
sumo-gui
```



- Download Instant Veins from <http://veins.car2x.org>
- Open Virtualization Format (OVA) image that can be imported in Virtual Box, VMWare, ...
- Already includes
  - OMNeT++ 5.3
  - SUMO 0.32.0
  - Veins 4.7.1
- Alternatively, download Instant Plexe from <http://plexe.car2x.org>
- Already includes
  - OMNeT++ 5.1.1
  - Plexe SUMO 2.1 (based on SUMO 0.32.0)
  - Plexe Veins 2.1 (based on Veins 4.7)
  - R



- In one terminal start the launch daemon (we'll see how to avoid this)

```
cd veins  
./sumo-launchd.py -c sumo-gui
```

- In a second terminal launch the example simulation

```
cd veins/examples/veins  
./run -u Cmdenv -c WithoutChannelSwitching -r 0
```

- The example simulates vehicles which
  - When stopping for more than 10 s, send a “Traffic congestion” message
  - Upon receiving such message a vehicle
    - Re-sends it to other vehicles
    - Chooses another route to its destination



- `examples/veins` folder:
  - Configuration files: `omnetpp.ini` (next slide), SUMO config, etc.
- `src/veins/modules/mobility/traci/TraciScenarioManagerLaunchd.ned`
  - Default values for `moduleType` and `moduleName`
    - `string moduleType = default("org.car2x.veins.nodes.Car");`
    - `string moduleName = default("node");`
- `src/veins/nodes/Car.ned`
  - Definition of a “car” node in OMNeT++
    - Compound module: application, NIC card, mobility module



```
[General]
```

```
[...]
```

```
network = RSUExampleScenario
```

```
[...]
```

```
*.manager.updateInterval = 1s  
*.manager.host = "localhost"  
*.manager.port = 9999  
*.manager.launchConfig = xmldoc("erlangen.launchd.xml")
```

```
[...]
```

```
*.rsu[0].mobility.x = 2000  
*.rsu[0].mobility.y = 2000  
*.rsu[0].mobility.z = 3  
*.rsu[*].applType = "TraCIDemoRSU11p"
```

```
[...]
```

Definition of the simulation network, which statically creates an 802.11p base station.

Nodes position update interval, and launch daemon parameters. The “forker” is a more handy way of launching the simulations.

Change `src/veins/nodes/Scenario.ned`:

- `import org.car2x.veins.modules.mobility.traci.TraCIScenarioManagerForker;`
- `manager: TraCIScenarioManagerForker {`

Change `omnetpp.ini` configuration:

- `*.manager.configFile = "erlangen.sumo.cfg"`
- `*.manager.commandLine = "sumo-gui --remote-port $port --seed $seed --configuration-file $configFile"`

Sets the position of the RSU and which application it runs. You have to search for the `TraCIDemoRSU11p`. `{ned,h,cc}` files



[...]

```
*.**.nic.mac1609_4.txPower = 20mW  
*.**.nic.mac1609_4.bitrate = 6Mbps  
*.**.nic.phy80211p.sensitivity = -89dBm  
*.**.nic.phy80211p.useThermalNoise = true  
*.**.nic.phy80211p.thermalNoise = -110dBm
```

Sets MAC/PHY layer parameters for ALL nodes, both RSU and cars. Tricky question: Why?

[...]

```
*.node[*].applType = "TraCIDemo11p"
```

Sets the application run by car nodes. You have to search for the TraCIDemo11p.{ned,h,cc} files

[...]

```
[Config WithBeaconing]
```

```
*.rsu[*].appl.sendBeacons = true  
*.node[*].appl.sendBeacons = true
```

Create a configuration named WithBeaconing and WithChannelSwitching. If no extends is specified, the configuration inherits from General

```
[Config WithChannelSwitching]
```

```
*.**.nic.mac1609_4.useServiceChannel = true  
*.node[*].appl.dataOnSch = true  
*.rsu[*].appl.dataOnSch = true
```



```
#include "veins/modules/application/traci/TraCIDemo11p.h"
```

```
Define_Module(TraCIDemo11p);
```

```
void TraCIDemo11p::initialize(int stage) {  
    BaseWaveApplLayer::initialize(stage);  
    if (stage == 0) {  
        sentMessage = false;  
        lastDroveAt = simTime();  
        currentSubscribedServiceId = -1;  
    }  
}
```



```
void TraCIDemo11p::handlePositionUpdate(cObject* obj) {
    BaseWaveApplLayer::handlePositionUpdate(obj);

    // stopped for for at least 10s?
    if (mobility->getSpeed() < 1) {
        if (simTime() - lastDroveAt >= 10 && sentMessage == false) {
            sentMessage = true;

            WaveShortMessage* wsm = new WaveShortMessage();
            populateWSM(wsm);
            wsm->setWsmData(mobility->getRoadId().c_str());

            //host is standing still due to crash
            if (dataOnSch) {
                startService(Channels::SCH2, 42, "Traffic Information Service");
                //started service and server advertising, schedule message to self to send later
                scheduleAt(computeAsynchronousSendingTime(1, type_SCH), wsm);
            }
            else {
                //send right away on CCH, because channel switching is disabled
                sendDown(wsm);
            }
        }
    }
    else {
        lastDroveAt = simTime();
    }
}
```





```
void TraCIDemo11p::onWSA(WaveServiceAdvertisement* wsa) {
    if (currentSubscribedServiceId == -1) {
        mac->changeServiceChannel(wsa->getTargetChannel());
        currentSubscribedServiceId = wsa->getPsid();
        if (currentOfferedServiceId != wsa->getPsid()) {
            stopService();
            startService((Channels::ChannelNumber) wsa->getTargetChannel(), wsa->getPsid(), "Mirrored Traffic
Service");
        }
    }
}

void TraCIDemo11p::onWSM(WaveShortMessage* wsm) {
    findHost()->getDisplayString().updateWith("r=16,green");
    //set a high delay on the congested road (avoid junctions ':')
    if (mobility->getRoadId()[0] != ':') traciVehicle->changeRoute(wsm->getWsmData(), 9999);
    if (!sentMessage) {
        sentMessage = true;
        //repeat the received traffic update once in 2 seconds plus some random delay
        wsm->setSenderAddress(myId);
        wsm->setSerial(3);
        scheduleAt(simTime() + 2 + uniform(0.01,0.2), wsm->dup());
    }
}
```



```
void TraCIDemo11p::handleSelfMsg(cMessage* msg) {
    if (WaveShortMessage* wsm = dynamic_cast<WaveShortMessage*>(msg)) {
        //send this message on the service channel until the counter is 3 or higher.
        //this code only runs when channel switching is enabled
        sendDown(wsm->dup());
        wsm->setSerial(wsm->getSerial() +1);
        if (wsm->getSerial() >= 3) { //stop service advertisements
            stopService();
            delete(wsm);
        }
        else {
            scheduleAt(simTime()+1, wsm);
        }
    }
    else {
        BaseWaveApplLayer::handleSelfMsg(msg);
    }
}
```